

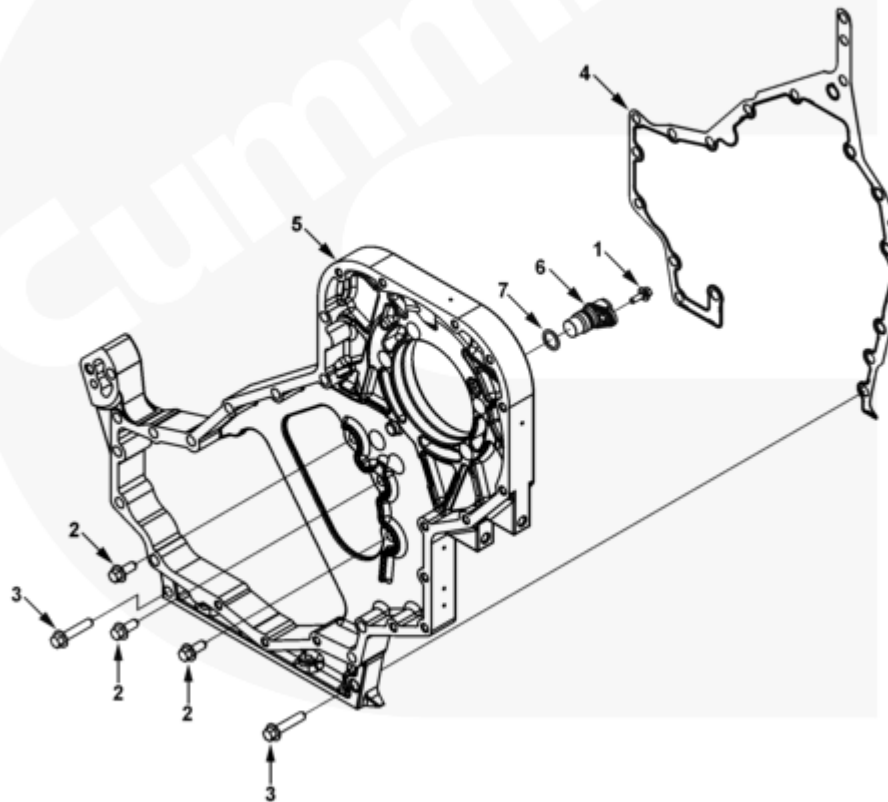

Parts Catalog - Option Detail

Electronic Parts Catalog - Option Detail				
Option	Group	Graphic	Film Card	Date
BB9837-04	01.01	bb902gi	Z	09-JUL-03
Engines	6C8.3, C GAS PLUS CM556, G8.3, G8.3 CM558, GTA8.3 CM558, ISC CM2150, ISC CM554, ISC CM850, ISC8.3 CM2250, ISC8.3 G CM2180 C101, ISL CM2150, ISL CM554, ISL CM850, ISL G CM2180, ISL8.9 CM2150 L110, ISL8.9 CM2880 L112, ISL9 CM2150 SN, ISL9 CM2250, ISL9 CM2350 L101, ISL9 CM2350 L111, ISLE4 CM850, L GAS PLUS CM556, L8.9, L8.9 L121, L8.9G CMOH2.0 L125B, L9 CM2350 L116B, L9 CM2350 L119B, L9 CM2350 L120C, L9 CM2350 L123B, L9.3 L105, L9.5 L117, L9N CM2380 L124B, QSC8.3 CM2250, QSC8.3 CM2880 C102, QSC8.3 CM554, QSC8.3 CM850(CM2850), QSL9 CM2250, QSL9 CM2250 L115, QSL9 CM2350 L102, QSL9 CM2350 L107, QSL9 CM2350 L118, QSL9 CM2350 L122, QSL9 CM554, QSL9 CM850(CM2850), QSL9 G CM558, QSL9 M CM2250 L106, QSL9.3 CM2880 L113			



bb902gi

Cart	Ref No	Part Number	Part Description	Required	Remarks
View My Cart					
		BB9837-04	Front Gear Housing		MR - HOUSING, FRONT GEAR...(More)
					Engine Family: Marine C
					Design Phase: Pegasus Alpha
					Drive Location: Gear Cover -
					Back
					Accessory Drive Pilot
					Bore (mm):: 101.6
					Centerline of Crank to
					Centerline of Accessory Drive
					Provision (mm): 99.5
					Centerline of Engine to
					Centerline of Accessory Drive
					Provision (mm): 247
					Gear Housing Mounting: 5 x
					M8 x 1.25
					Gear Housing Accessory Drive
					Mounting Provision: 2 x M12
					x 1.75
					Gear Housing Accessory Drive
					Mounting Bolt Circle
					Diameter (mm): 146
					Fuel Pump Pilot Bore
					(mm): 107
					Centerline of Crank to
					Centerline of Fuel Pump Drive
					Provision (mm): 317.7
					Centerline of Engine to
					Centerline of Fuel Pump Drive

					Provision (mm): 209
					Fuel Pump Mounting
					Provision: 4 x M10 x 1.5
					Fuel Pump Mounting Bolt
					Circle Diameter (mm): 130
					Unique Characteristics:
					Please Locate Gear Housing
					Plug in the Inboard Location
					for Position Sensor (i.e.
					Location Nearer the Block)
<input type="checkbox"/>	2	3926846	Hexagon Flange Head Cap Screw	3	M8 X 1.25 X 20.
<input type="checkbox"/>	3	3943885	Hexagon Flange Head Cap Screw	2	M8 x 1.25 x 40
<input type="checkbox"/>	4	3944293	Gear Housing Gasket	1	
		3968053	Gear Housing	1	
<input type="checkbox"/>	1	3913638	Hexagon Flange Head Cap Screw	1	M6 X 1.00 X 16.
<input type="checkbox"/>	5	3945853	Gear Housing	1	
<input type="checkbox"/>		3968702	Gear Housing Plug	1	
<input type="checkbox"/>	6	3968703	O-Ring Plug	1	
<input type="checkbox"/>	7	4010643	O-Ring Seal	1	